



Description

HY2595 of regulators provides all the active functions for a step-down (buck) switching regulator, and drives 2.2A load with excellent line and load regulation. HY2595 is available in fixed output voltages of 5V and an adjustable output version.

Regulators are simple to use and require a minimum number of external components. Features include internal frequency compensation and a fixed-frequency oscillator.

The HY2595 is high-efficiency replacements for popular three-terminal linear regulators, and requiring a smaller heat-sink or even no heat-sink.

HY2595 performs well with standard inductors from several manufacturers and simplifying the design of switch mode power supplies. HY2595 guarantees 4% tolerance on output voltage within specified input voltages and output load conditions and 15% on the oscillator frequency.

External shut-down is included with typical 100uA (typical) standby current. The output switch has cycle-by-cycle current limiting as well as thermal shut-down for full protection under fault conditions

HY2595 operates at a switching frequency of 150 kHz thus allowing smaller size filter components than what would be needed with lower frequency switching regulators. HY2595 is available in SOIC-8L package.

Features

- n** Output voltage range, 1.2V to 37V with $\pm 4\%$ max over line and load conditions
- n** 2.2A output load current
- n** Input voltage range up to 40V
- n** Requires only 4 external components
- n** 150 kHz fixed frequency internal oscillator
- n** TTL shutdown capability
- n** Low power standby mode, typically 100 uA.
- n** High efficiency
- n** Uses readily available standard inductors
- n** Thermal shutdown and current limit protection

Applications

- n** Simple high-efficiency step-down (buck) regulator
- n** Pre-regulator for linear regulators.
- n** On-card/boards witching regulators
- n** Positive to negative converter (buck-boost).



TYPICAL APPLICATION

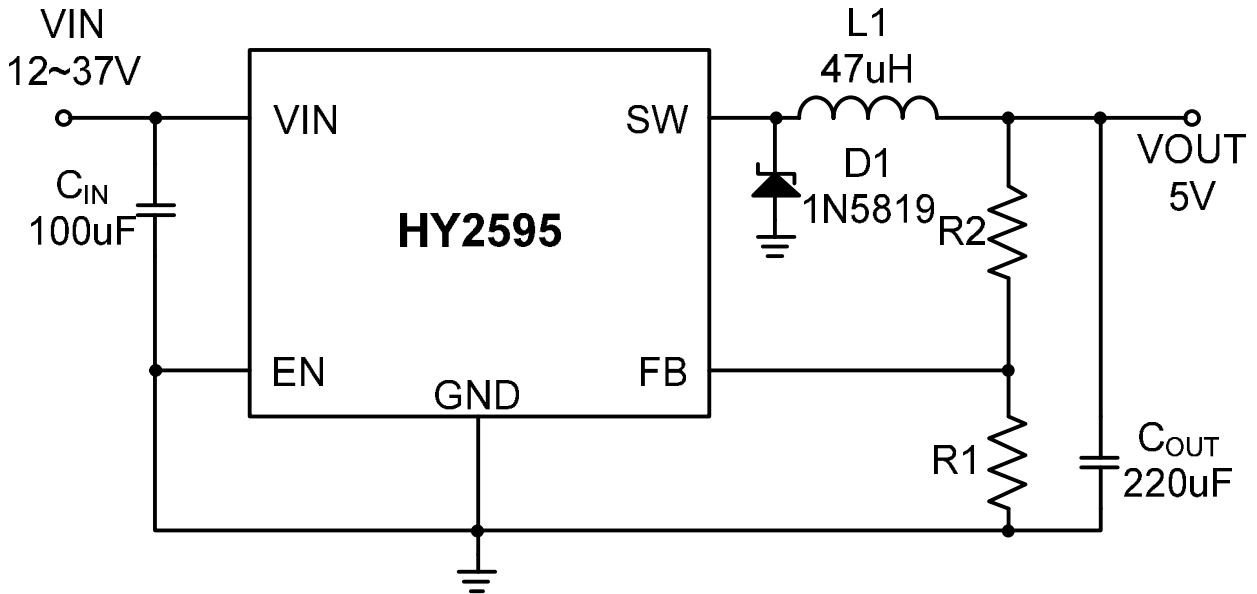

Marking Information & Pin Configuration

SOP-8L

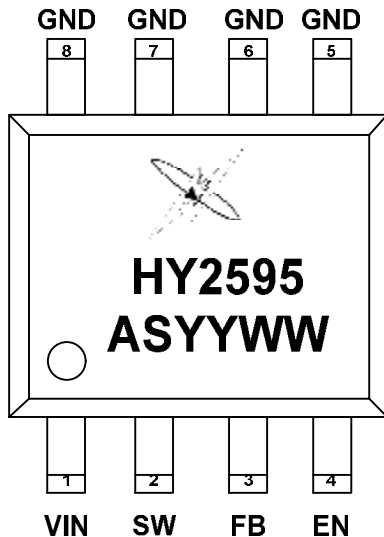

A: Output Voltage
 (A=ADJ)
 S : Assembly Information
 YY : Year
 WW : Weekly

Pin Definition

PIN SYMBOL	PIN DESCRIPTION
VIN	The positive input supply for the IC switching regulator. A suitable input bypass capacitor must be present at this pin to minimize voltage transients and to supply the switching currents needed by the regulator.
SW	Internal switch. The voltage at this pin switches between (+VIN –VSAT) and approximately –0.5V, with a duty cycle of approximately VOUT/VIN. To minimize coupling to sensitive circuitry, the PC board copper area connected to this pin should be kept to a minimum.
FB	Senses the regulated output voltage to complete the feedback loop.
EN	Allows the switching regulator circuit to be shut down using logic level signals thus dropping the total input supply current to approximately 100µA. Pulling this pin below a threshold voltage of approximately 1.3V turns the regulator on, and pulling this pin above 1.3V (up to a maximum of 25V) shuts the regulator down. If this shut down feature is not needed, the EN pin can be wired to the ground pin or it can be left open, in either case the regulator will be in the ON condition.
GND	Circuit ground.

Block Diagram

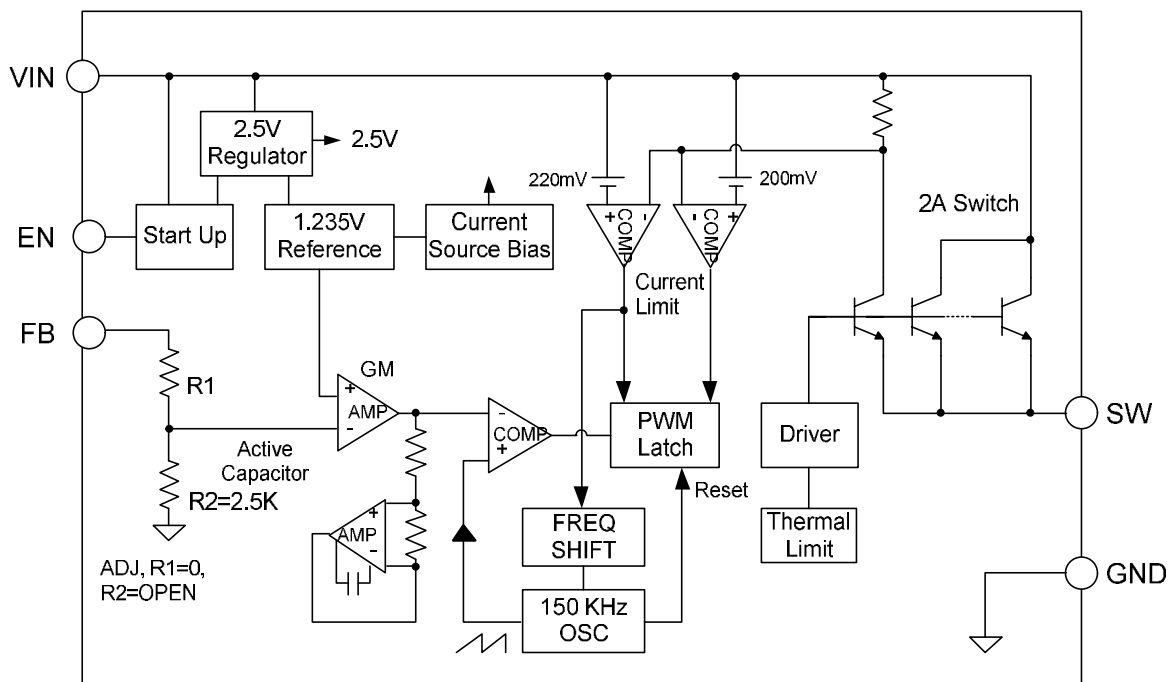



ABSOLUTE MAXIMUM RATINGS

RATING	VALUE	UNIT
Maximum Supply Voltage	45	V
EN/FB Input Voltage	-0.3 to 25	V
Power Dissipation	Internally Limited	
Output Voltage to Ground (Steady State)	-0.9	V
Maximum Junction Temperature Range	150	°C
Storage Temperature Range	-65 to 150	°C

ELECTRICAL CHARACTERISTICS

HY2595-ADJ

(TA = 25°C, UNLESS OTHERWISE SPECIFIED)

PARAMETER	CONDITION	MIN	TYP	MAX	UNIT
Feedback Voltage	4.5V < VIN < 40V, 0.2A < ILOAD < 2.2A	1.193 1.180	1.23	1.267 1.280	V
Efficiency	VIN=12V, ILOAD=2.2A		80		%

(Specifications with standard type face are for T= 25 °C , and those with apply over full Operating Temperature Range. Unless otherwise specified, V=12V for the ADJ version. I=500mA)

General					
PARAMETER	CONDITION	MIN	TYP	MAX	UNIT
Feedback Bias Current	V _{FB} =1.3V(Adjustable Version Only)	-	15	100	nA
Oscillator Frequency	(Note 6.)	127	150	173	KHz
Saturation Voltage	I _{OUT} =2.2A (Note 7,8.)	-	1.7	2	V
Max Duty Cycle	(Note 8.)	-	100	-	%



2.2A 150kHz DC-DC BUCK REGULATOR

Current Limit	Peak Current (Note 9.)	3.4	4.5	6	A
Output Leakage Current	Output=0V Output=-0.9V	-	- 0.3	50 1	μA mA
EN Pin Logic Input Level	Low (Function Enable) High (Function Disable)	- 2	1.3	0.6 -	V
EN Pin Input Current	V _{EN} =2.5V(Function Enable) V _{EN} =0.5V(Function Disable)		5 0.02	15 5	μA
Quiescent Current	(Note 9.)	-	5	7	mA
Standby Current	V _{EN} = 5.0V (Note 10.)		60	100	μA

Note

1. Absolute Maximum Ratings indicate limits beyond which damage to the device may occur. Operating Ratings indicate condition for which the device is intended to be functional, but do not guarantee specific performance limits. For guaranteed specifications and test conditions, see the Electrical Characteristics.
2. The human body model is a 100pF capacitor discharged through a 1.5k resistor into each pin.
3. Typical numbers are at 25°C and represent the most likely norm.
4. All limits guaranteed at room temperature (stand are type) face and at temperature extremes (bold type face). All room temperature limits are 100% production tested.
All limits at temperature extremes are guaranteed via correlation using standard Statistical Quality Control (SQC) methods.
All limits are used to calculate Average Out going Quality Level (AOQL).
5. External components such as the catch diode, inductor, input and output capacitors and voltage programming resistors can affects witching regulator system performance. When the HY2595 is used as shown in the Figure test circuit system performance will be as shown in system parameters section of Electrical Characteristics.
6. The switching frequency is reduced when the second stage current limit is activated.
7. No diode inductor or capacitor connected to output pin.
8. Feedback pin removed from output and connected to 0V to force the output transistor switch ON.
9. Feedback pin removed from output and connected to 12V for the 5V and the ADJ version to force the output transistor switch OFF.
10. V_{IN}=40V



TEST CIRCUIT AND LAYOUT GUIDELINES

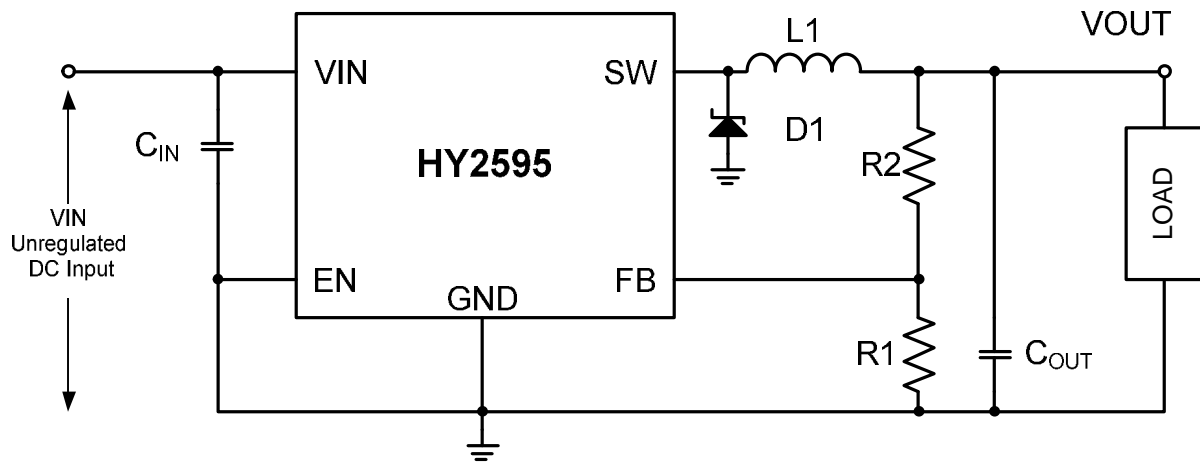

C_{IN} - 470uF/50V

C_{OUT} - 220uF/25V

L1 - 68uH

D1 - 3A/40V Schottky Diode

R1 - 1KΩ 1%

$V_{OUT} = 5V$, R2 - 3.06KΩ 1%

$$V_{OUT} = V_{REF} \left(1 + \frac{R_2}{R_1} \right)$$

$$R_2 = R_1 \times \left(\frac{V_{OUT}}{V_{REF}} - 1 \right)$$

Where $V_{REF}=1.23V$, R1 approximately 1KΩ 1%

Test Circuit

Careful layout is important with any switching regulator. Rapidly switching currents associated with wiring inductance generate voltage transients which can cause problems. To minimize inductance and ground loops, the lengths of the leads indicated by heavy lines should be kept as short as possible. Ground plane construction should be used for best results. When using the Adjustable version, place the programming resistors as close as possible to HY2595 to keep the sensitive feedback wiring short.



PERFORMANCE CHARACTERISTICS

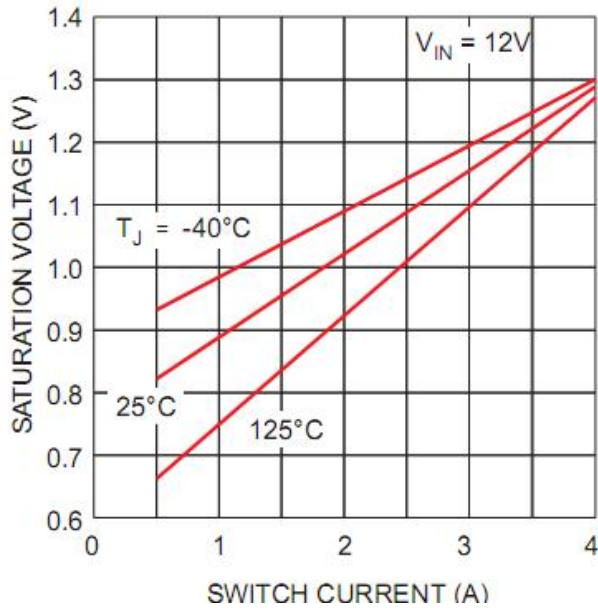

Switch Saturation Voltage

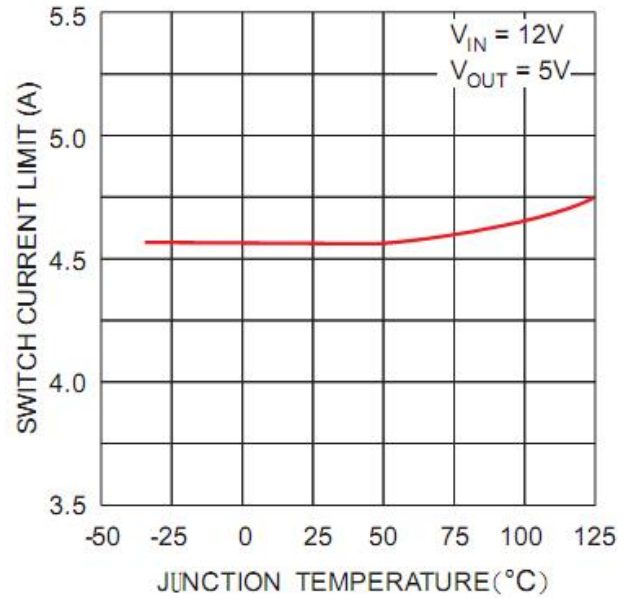

Switch Current Limit

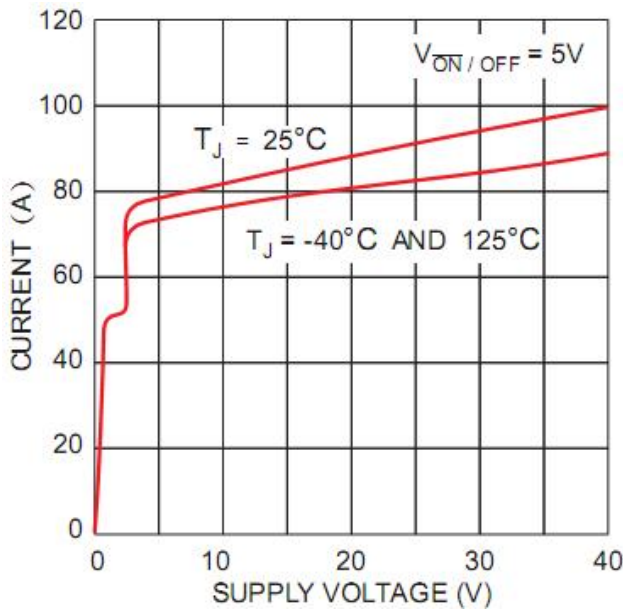

Shutdown Quiescent Current

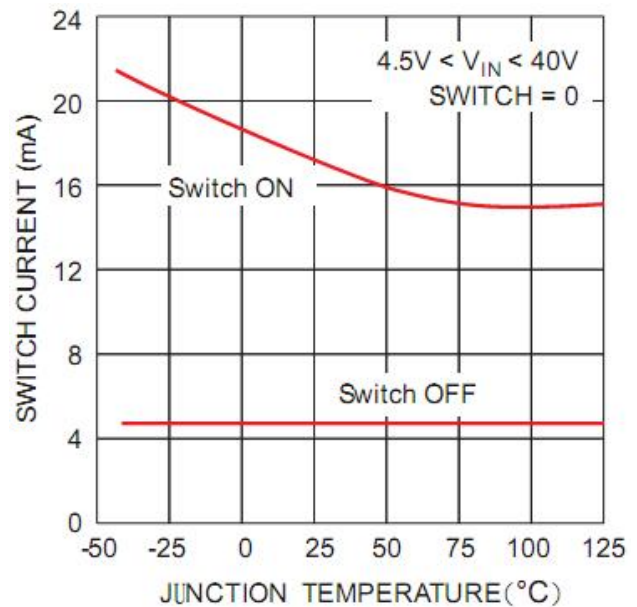

Operating Quiescent Current

APPLICATION INFORMATION

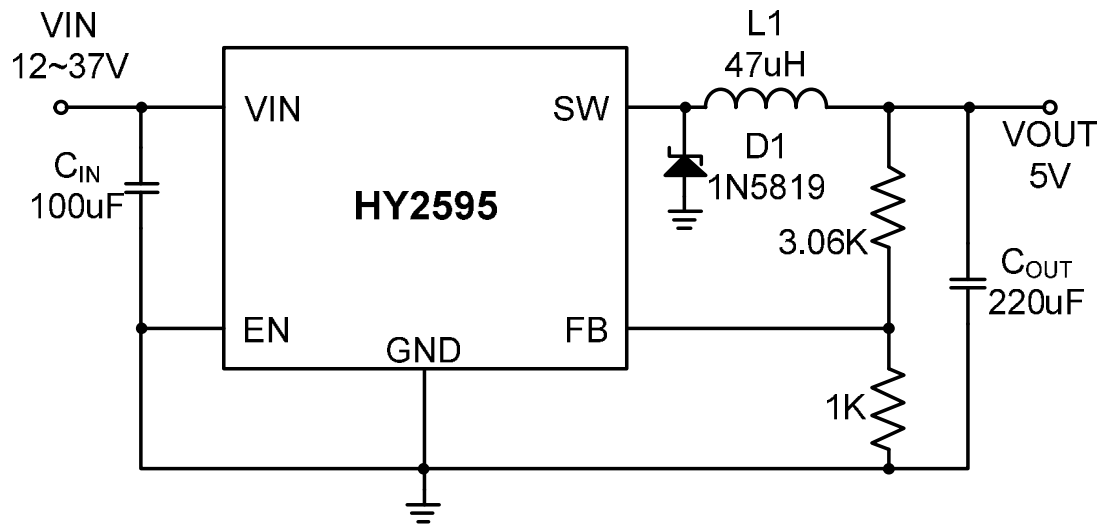

Step Down (Buck) Regulator with Adjustable Version for Output Voltage 5V

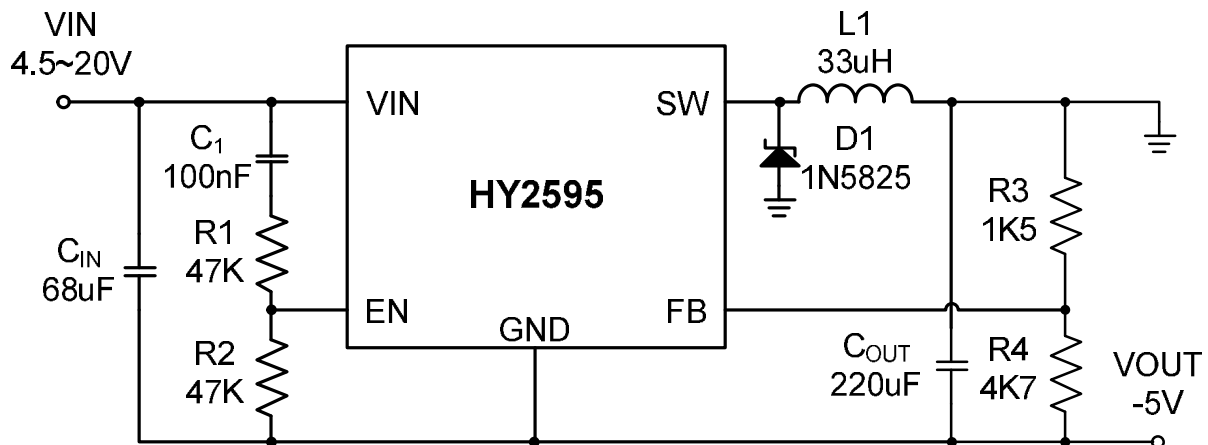

Inverting -5V Regulator with Delayed Startup

The circuit in above figure uses the EN pin to provide a time delay between the time of the input voltage is applied and the time of the output voltage comes up (only the circuitry pertaining to the delayed startup is shown). As the input voltage rises, the charging of capacitor C1 pulls the EN pin high, keeping the regulator off. Once the input voltage reaches its final value and the capacitor stops charging, and resistor R2 pulls the EN pin low, thus allowing the circuit to start switching. Resistor R1 is included to limit the maximum voltage applied to the EN pin (maximum of 25V), reduces power supply noise sensitivity, and also limits the capacitor C1 discharge current. When high input ripple voltage exists, avoid long delay time, because this ripple can be coupled into the EN pin and cause problems.

2.2A 150kHz DC-DC BUCK REGULATOR

This delayed startup feature is useful in situations where the input power source is limited in the amount of current it can deliver. It allows the input voltage to rise to a higher voltage before the regulator starts operating. Buck regulators require less input current at higher input voltages

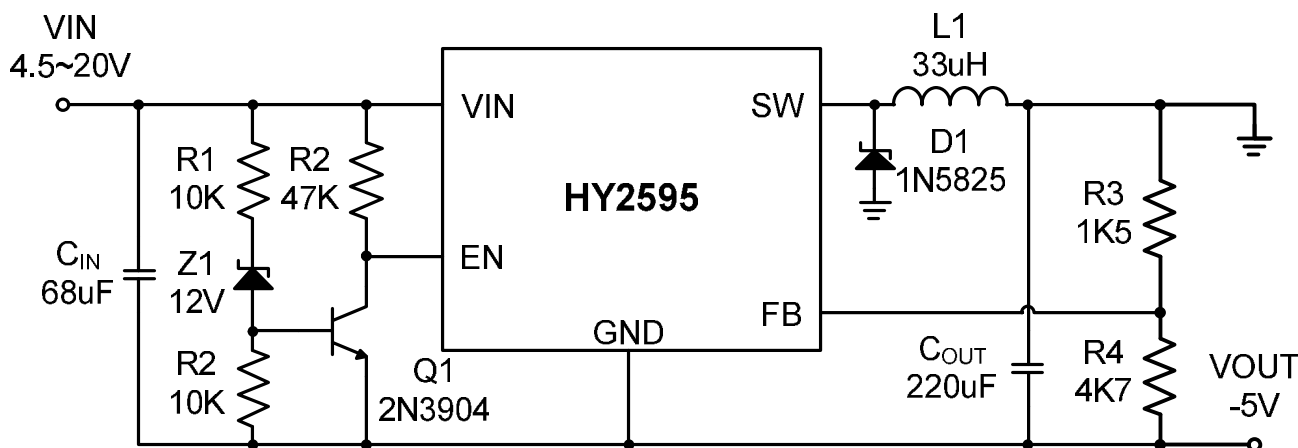

This circuit has hysteresis
 Regulator starts switching at $V_{IN} = 13V$
 Regulator stops switching at $V_{IN} = 8V$

Under voltage Lockout with Hysteresis for Inverting Regulator

Some applications require the regulator to remain off until the input voltage reaches a predetermined voltage. An under voltage lockout feature applied to a buck regulator is shown in above figure, while applies the same feature to an inverting circuit. The circuit in above figure features a constant threshold voltage for turn on and turn off (zener voltage plus approximately one volt). If hysteresis is needed, the circuit in above figure has a turn ON voltage which is different than the turn OFF voltage. The amount of hysteresis is approximately equal to the value of the output voltage. If zener voltages greater than 25V are used, an additional 47k Ω resistor is needed from the EN pin to the ground pin to stay within the 25V maximum limit of the EN pin.



Package Outline Dimensions

SOP-8L PACKAGE OUTLINE DIMENSIONS

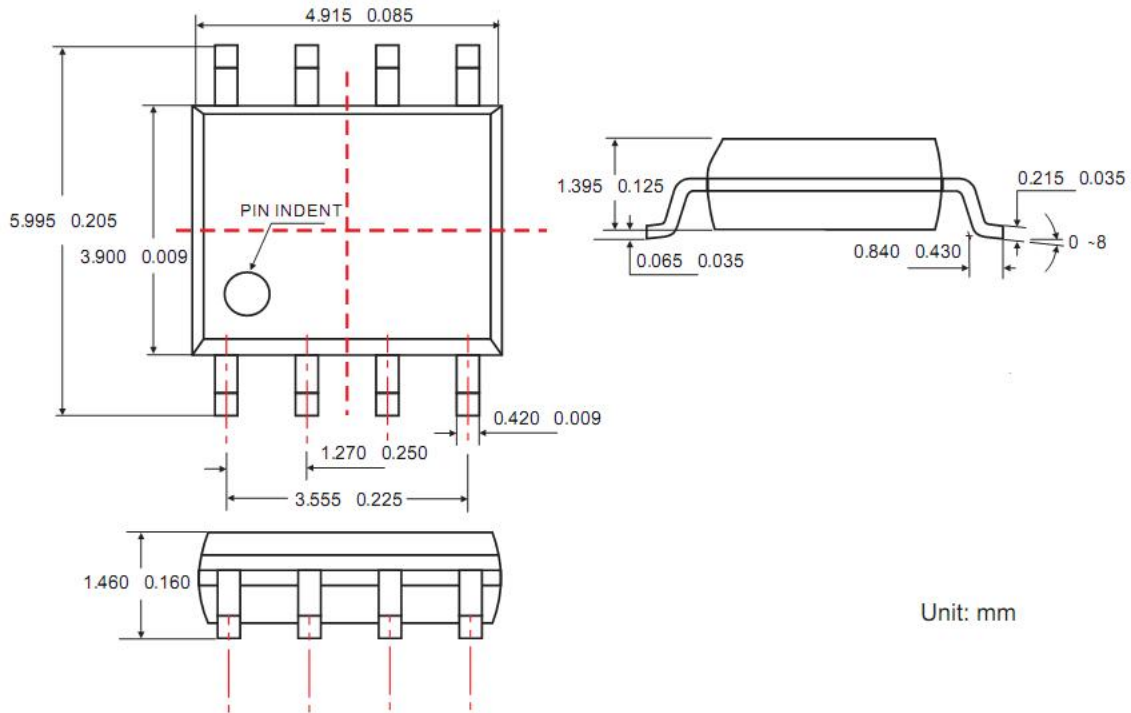

Unit: mm

ORDERING INFORMATION

HY2595 S8 R

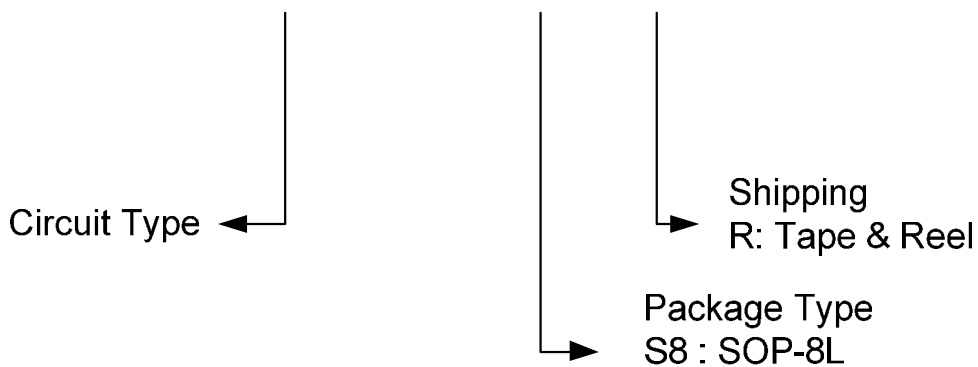

ORDERING REMEMBER	OUTPUT VOLTAGE	PACKAGE	SHIPPING
HY2595S8R	ADJUSTABLE	SOP-8L	3,000 Units/ Tape & Reel